

C-MOS 16-BIT A/D, D/A CONVERTER

—TOP VIEW—

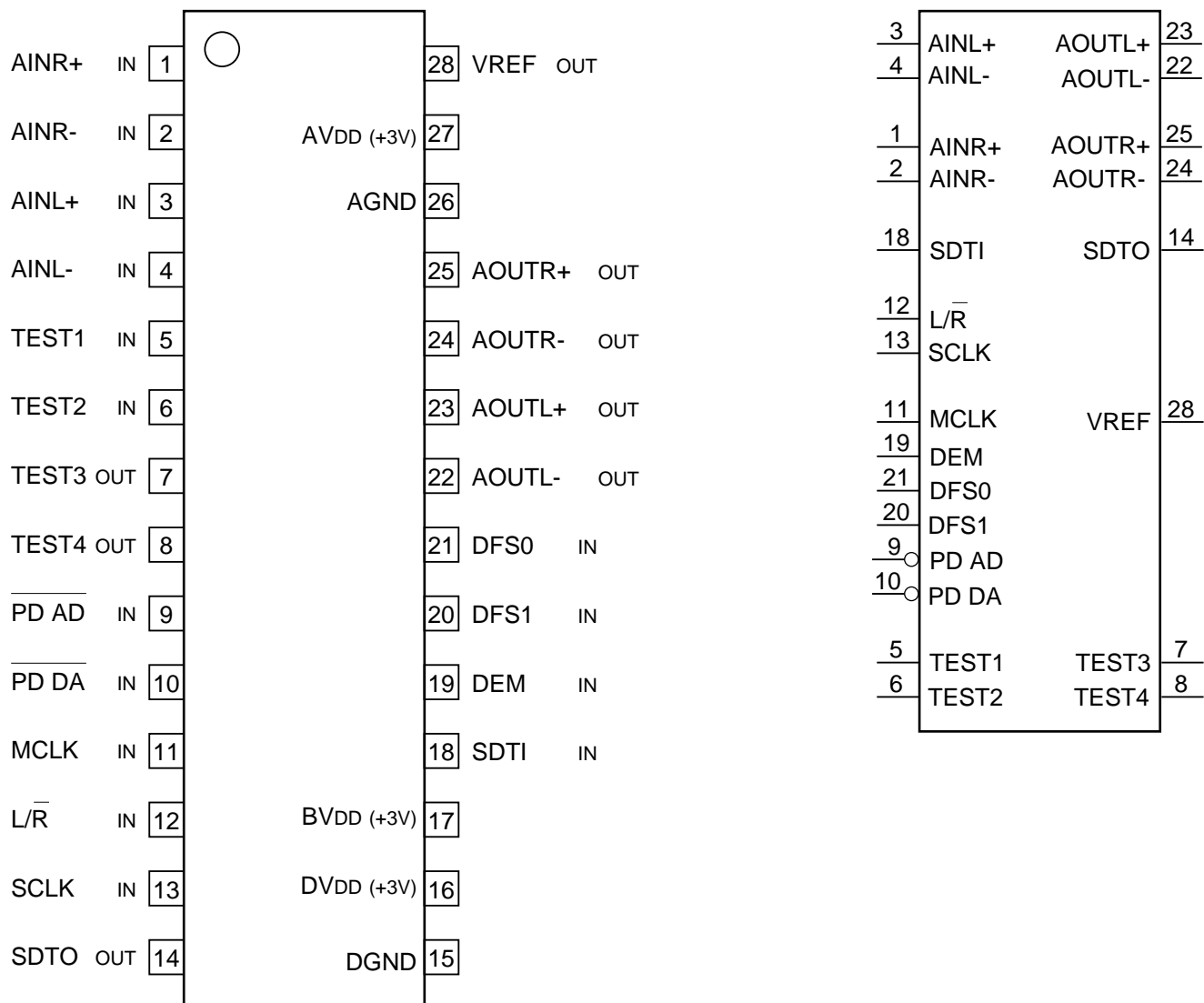
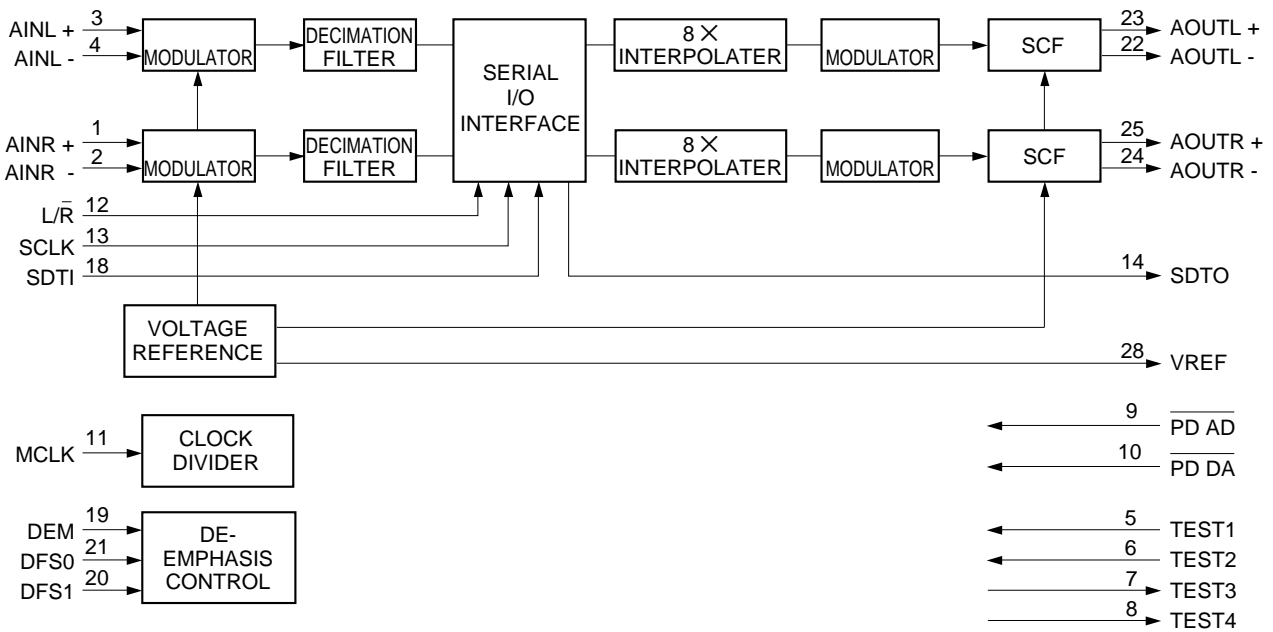

**INPUT**

AINL + ; CHANNEL L ANALOG POSITIVE INPUT
 AINL - ; CHANNEL L ANALOG NEGATIVE INPUT
 AINR + ; CHANNEL R ANALOG POSITIVE INPUT
 AINR - ; CHANNEL R ANALOG NEGATIVE INPUT
 DEM ; DE-EMPHASIS CONTROL
 DFS0, DFS1 ; DE-EMPHASIS FREQUENCY SELECT
 L / R ; INPUT/OUTPUT CHANNEL SELECT
 MCLK ; MASTER CLOCK
 PD AD ; A/D CONVERTER POWER DOWN
 PD DA ; D/A CONVERTER POWER DOWN
 SCLK ; SERIAL DATA CLOCK
 SDTI ; SERIAL DATA
 TEST1, TEST2 ; TEST

OUTPUT

AOUTL + ; CHANNEL L ANALOG POSITIVE OUTPUT
 AOUTL - ; CHANNEL L ANALOG NEGATIVE OUTPUT
 AOUTR + ; CHANNEL R ANALOG POSITIVE OUTPUT
 AOUTR - ; CHANNEL R ANALOG NEGATIVE OUTPUT
 SDTO ; SERIAL DATA
 TEST3, TEST4 ; TEST
 VREF ; REFERENCE VOLTAGE